

Pedal Box Rattle/Squeak –
Loose/Broken Rivets –
Repair Procedure

MODEL 2002 MY-ON
X-TYPE

VIN C00001-ON

Issue:

Some X-TYPE vehicles may exhibit a rattle or squeak emanating from the clutch or brake pedal area.

Cause:

One or both rivets retaining the brake/clutch switch brackets to the pedal box bracket becoming loose, or breaking.

Action:

To install new brake/clutch switch bracket to pedal box bracket rivets, follow the repair procedure outlined below.

REPAIR PROCEDURE

1. Automatic vehicles only: proceed to step 7.
2. Manual vehicles only: Detach the clutch pedal switch (Illustration 1).

CLUTCH PEDAL SWITCH

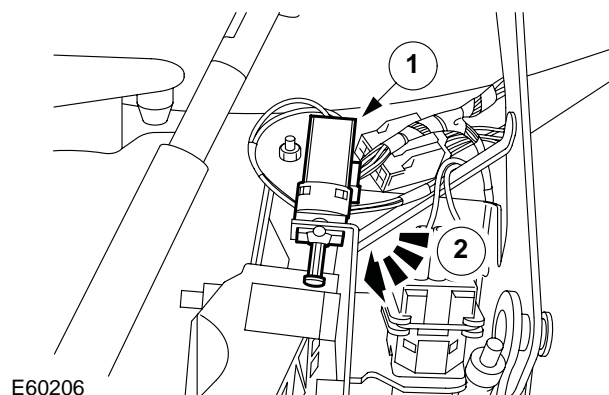

ILLUSTRATION 1

NOTE: THE INFORMATION IN TECHNICAL BULLETINS IS INTENDED FOR USE BY TRAINED, PROFESSIONAL TECHNICIANS WITH THE KNOWLEDGE, TOOLS, AND EQUIPMENT TO DO THE JOB PROPERLY AND SAFELY. IT INFORMS THESE TECHNICIANS OF CONDITIONS THAT MAY OCCUR ON SOME VEHICLES, OR PROVIDES INFORMATION THAT COULD ASSIST IN PROPER VEHICLE SERVICE. THE PROCEDURES SHOULD NOT BE PERFORMED BY "DO-IT-YOURSELFERS." DO NOT ASSUME THAT A CONDITION DESCRIBED AFFECTS YOUR CAR. CONTACT A JAGUAR DEALER TO DETERMINE WHETHER THE BULLETIN APPLIES TO YOUR VEHICLE.

3. Manual vehicles only: Remove the clutch pedal return spring clip (Illustration 2).

CLUTCH PEDAL RETURN SPRING CLIP

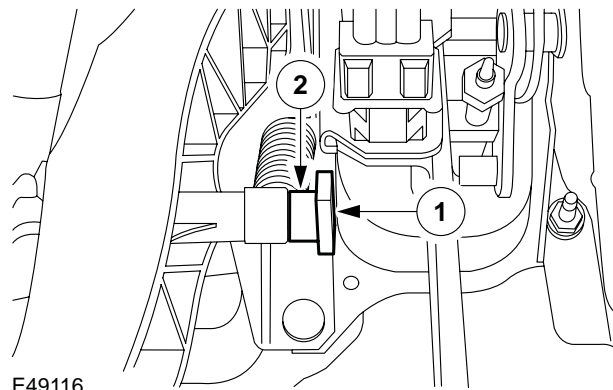

ILLUSTRATION 2

4. Manual vehicles only: Remove the clutch pedal return spring (Illustration 3).

REMOVE CLUTCH PEDAL RETURN SPRING

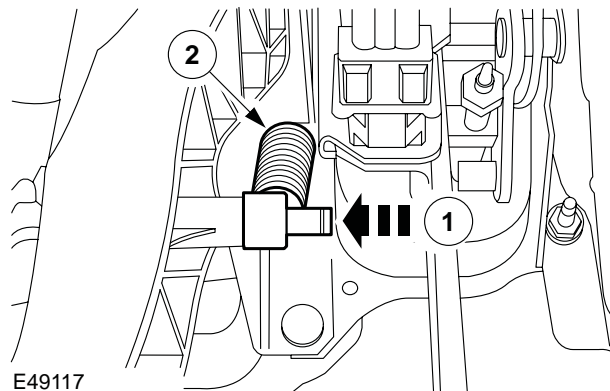

ILLUSTRATION 3

5. Manual vehicles only: Remove the clutch pedal pivot support nut (Illustration 4).

CLUTCH PEDAL PIVOT SUPPORT NUT

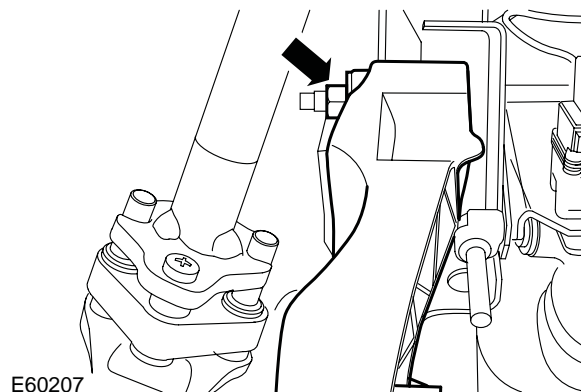

ILLUSTRATION 4

- Manual vehicles only: Remove the pedal from the clutch master cylinder (Illustration 5).

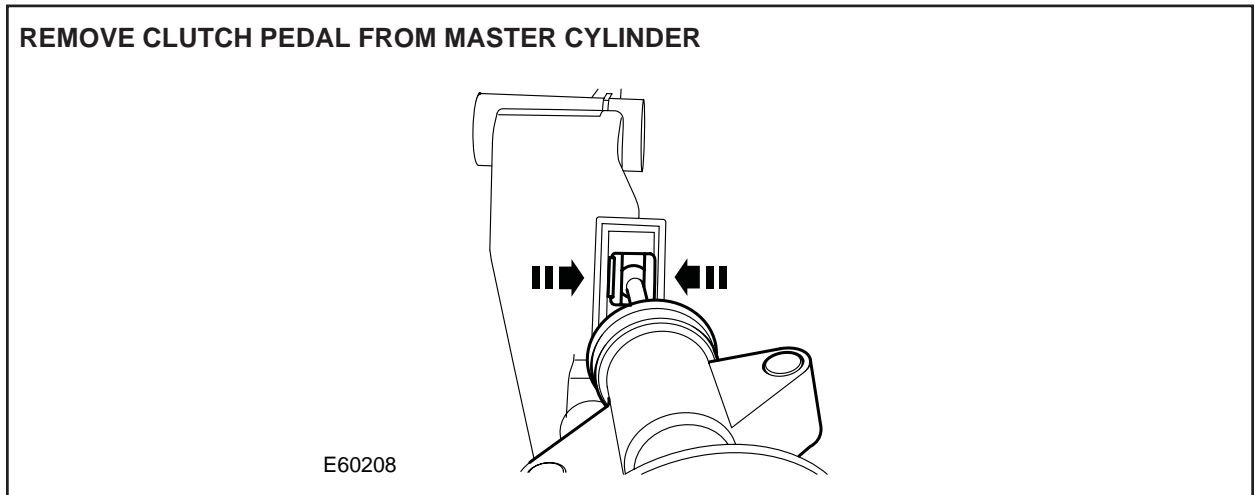

ILLUSTRATION 5

⚠ Caution: Make sure the rivets are correctly seated and the riveting device is positioned squarely onto the rivets before the rivets are secured. Failure to follow this instruction may result in damage to the vehicle.

- All Vehicles: Remove the old rivets and replace with new rivets one at a time (Illustration 6).

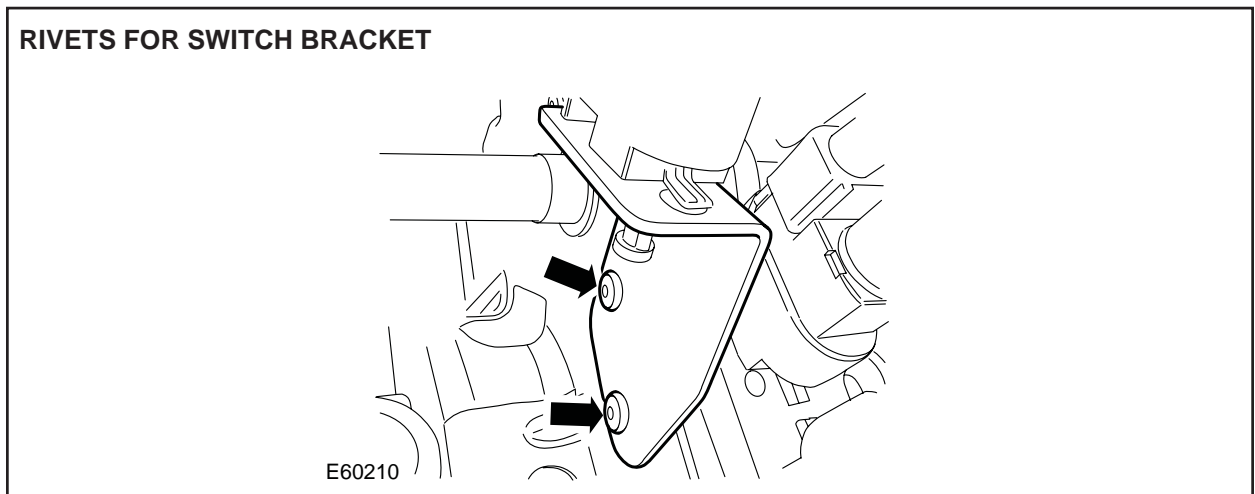

ILLUSTRATION 6

- Manual vehicles only: Connect the pedal to the clutch master cylinder.
- Manual vehicles only: Install the clutch pedal pivot securing nut.
- Manual vehicles only: Install the clutch pedal return spring.
- Manual vehicles only: Install the clutch pedal return spring clip.
- Manual vehicles only: Attach the clutch pedal switch.

Global Technical Reference (GTR) Workshop Manual Information:

Dealer access: <https://hub.franchise.jaguar.com>

Internet access: <http://www.jaguartechno.com>

Parts Information:

<u>DESCRIPTION</u>	<u>PART NUMBER</u>	<u>QTY</u>
Rivet	C2S 42082	2

Warranty Information:

Warranty claims should be submitted quoting the information found in the table below. This will result in payment of the stated time and, where applicable parts/miscellaneous expense codes as listed.

Description	SRO	Time	Causal Part Number
Install new brake/clutch pedal rivets - Manual	70.91.33	0.2 hrs.	C2S 42082
Install new brake/clutch pedal rivets - Automatic	70.91.33	0.2 hrs.	C2S 42082